



Project _____
 Item # _____
 Quantity _____

Countertop Refrigerated Cold Beverage Displays

Models: CRD-1, CRD-1K

With its clear panels and 4 LED light strips, this countertop display can keep up to 100 standard, 12oz cans chilled.

Standard Features

- ◆ Digital temperature controller from 32°F to 39°F
- ◆ 360° view of refrigerated product
- ◆ 2 double-glass doors for dual access and easy placement of inner contents
- ◆ 4 LED strips for effective product lighting
- ◆ Comfortably fits up to 100 cans (standard 12 oz), with 25 cans per shelf
- ◆ 4 levels of durable PVC-coated shelves; three (3) are adjustable to fit multiple product heights
- ◆ Automatic defrost and ventilated cooling system
- ◆ ETL listed for electrical safety and sanitation in US and Canada, conforms to UL-197 and CSA C22.2
- ◆ One year parts and labor warranty



The grate below door
flips down to access
On/Off switch



IMPORTANT

This unit is intended for use in commercial food-service operations, for the cooling and display of sealed food and beverage only.



Countertop Refrigerated Cold Beverage Displays

Models: CRD-1, CRD-1K

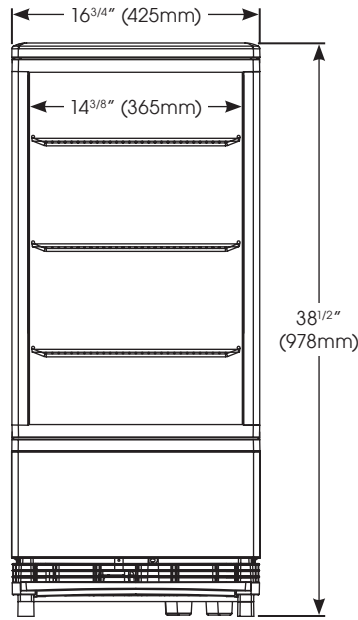

FRONT VIEW

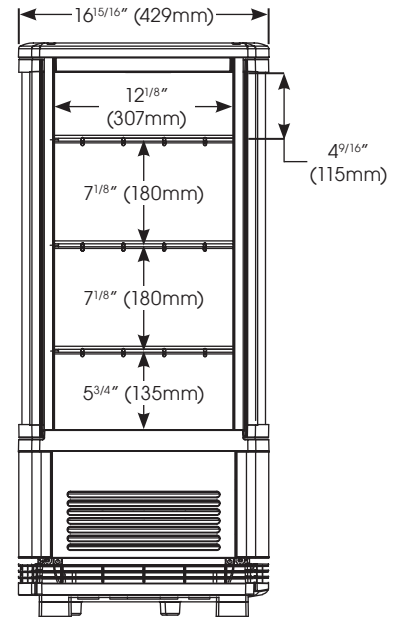

SIDE VIEW

Specifications

MODEL	DESCRIPTION	OVERALL DIMENSIONS			VOLTS	HZ	WATTS	AMPS	PLUG	SHIP WEIGHT
		WIDTH	DEPTH	HEIGHT						
CRD-1	White	16-3/4" (425mm)	16-15/16" (429mm)	38-1/2" (978mm)	110 - 120	60	230	2.7	NEMA 5-15P	85.89 lbs (39 kgs)
		SHELF DIMENSIONS								
CRD-1K	Black	14-3/8" (365mm)	12-1/8" (307mm)							

Cannot be shipped by UPS®

Capacity

100 cans (12 oz) / 25 cans per shelf

Cord Location

Side panel, lower left (from front view)

Plug Configuration

NEMA 5-15P

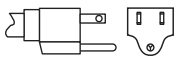

Product Specs

Countertop Refrigerated Cold Beverage Displays

The Countertop Refrigerated Cold Beverage Displays, models CRD-1 and CRD-1K, manufactured by Winco®, Lodi, NJ 07644.

The Refrigerated Displays shall be rated at 120V-60Hz, 230 watts. They shall consist of four (4) durable PVC-coated shelves, four (4) LED strips, two (2) double-glass doors.

Digital temperature controller ranges from 32°F to 39°F. Automatic defrost. Ventilated cooling system.

This unit is intended for use in commercial food-service operations, for the cooling and display of sealed food and beverage only.

ETL listed for electrical safety and sanitation in US and Canada, conforms to UL-197 and CSA C22.2.

Warranty consists of one year parts and labor.

redriverkitchens.com
doug@redriverkitchens.com
214-843-7078