



Project \_\_\_\_\_

Item # \_\_\_\_\_

Quantity \_\_\_\_\_

# SPECTRUM Electric Countertop Conveyor Toaster

Model: ECT-700 (700 slices per hour)

The SPECTRUM CONVEYOR TOASTER is the ideal choice for serving perfectly toasted breads, bagels, small pizzas and similar dough-based products. This easy-to-operate unit can keep pace with even the busiest kitchens and buffets. The belt-speed dial allows control over doneness, and the top & bottom heating elements can be on simultaneously or independently.

The specially designed return ramp is rounded, extra-wide and ideal for over-sized bagels. Features an easy-load rack, front return chute, as well as optional rear product return.

### Standard Features

- ◆ Toasts up to 700 slices per hour
- ◆ Heavy duty all stainless steel "Cool-Touch" exterior
- ◆ Large 2-1/2" high feeder opening with a 10-3/8" (2 slice) wide conveyor accepts over-sized bagels and Texas Toast
- ◆ Rounded, extra-wide curved return chute prevents larger foods items from getting caught
- ◆ Variable conveyor-speed dial control for optimal doneness
- ◆ Choose between independent or dual-heating elements for added flexibility
- ◆ Energy Saver-Hold mode saves up to 75 percent energy during slow periods when unit is not in use and allows quick recovery to temperature.
- ◆ Removable crumb tray
- ◆ Adjustable legs with non-skid foot add stability
- ◆ One year parts and labor warranty



ECT-700



### Parts

ECT700-P1	Return Chute
ECT700-P2	Adjustable Leg
ECT700-P11	Conveyor Belt
ECT700-P12	Pass-Through Chute
ECT700-P13	Back Baffle Plate
ECT700-P15	Heating Element - UPPER
ECT700-P16	Heating Element - LOWER
ECT700-P21	Control Knob - ON/OFF
ECT700-P22	Control Knob - DONENESS
ECT700-P26	Crumb Tray
ECT700-P27	Feeder Rack

### Accessories

BGS-1	Bagel Slicer
SPBR-604	Butter Roller
TWP-31	Sandwich Spreader
TWP-31P	Sandwich Spreader, Purple, Allergen-Free
SCPH-33	Condiment Packet Holder



## Electric Countertop Conveyor Toaster

Model: ECT-700

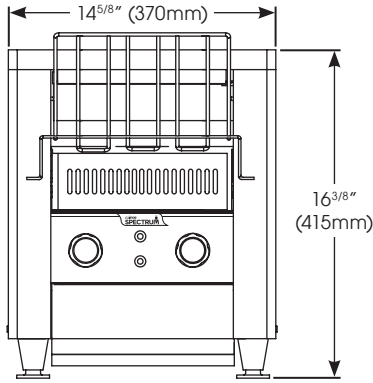

FRONT VIEW

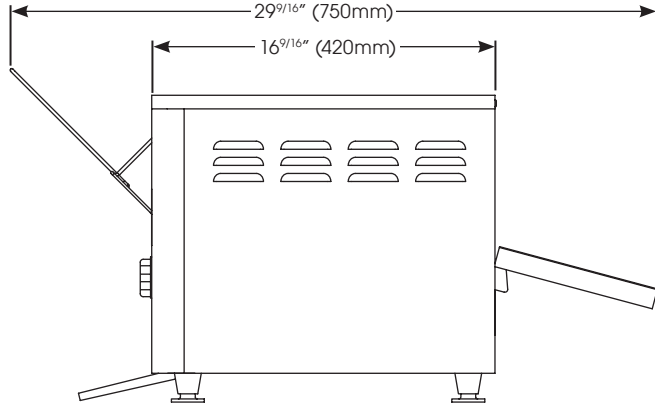

SIDE VIEW

MODEL	DESCRIPTION	OVERALL DIMENSIONS			VOLTS	HZ	WATTS	AMPS	PLUG	SHIP WEIGHT
		LENGTH	DEPTH	HEIGHT						
ECT-700	Slices per Hour 700	14-5/8" (370mm)	16-9/16" (420mm)	16-3/8" (415mm)	208/240	50/60	1800/2400	8.6/10	NEMA 6-15P	44.53 lbs (20.2 kgs)

### Cord Location

Bottom of unit on left side

### Plug Configuration

NEMA 6-15P

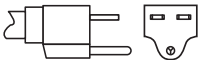

### Product Specs

#### Electric Countertop Conveyor Toaster

The Electric Countertop Conveyor Toaster model ECT-700 as manufactured by Winco®, Lodi, NJ 07644

The Electric Countertop Conveyor Toaster shall have the capacity to toast up to 700 slices per hour and shall be rated at 1800/2400 Watts, 208/240V~50/60Hz/1 and supplied with a NEMA 6-15P plug. Units shall be constructed of stainless steel with a cool-touch exterior and be equipped with a large 2-1/2" high feeder opening with a 10-3/8" (2 slice) wide conveyor, rounded extra-wide curved return chute, variable conveyor-speed dial control for optimal doneness, independent or dual-heating elements control, energy saver-hold mode, removable crumb tray, and adjustable legs with non-skid foot.

ETL listed for safety (Canada & US) and sanitation.

Warranty consists of one year parts and labor.



214-843-7078



doug@redriverkitchens.com



redriverkitchens.com



Serving North Texas