



Project \_\_\_\_\_  
 Item # \_\_\_\_\_  
 Quantity \_\_\_\_\_

# SPECTRUM

## Commercial Countertop Gas Hot Plates, Natural / LP

Models: NGHP-2 / NGHP-4 / NGHP-6

The Spectrum Gas Hot Plates are designed with durable stainless steel construction and cool-touch front plate rail.

These units are equipped with infinite heat controls, high-performance burners, heavy-duty cast iron top grates, removable grease/drip pan.

Includes an LP conversion kit.

### Standard Features

- ◆ High performance burners, each with output of 25,000 BTU
- ◆ Infinite heat controls
- ◆ Stainless steel body, adjustable legs 4" to 6" and drip pan; non-skid feet
- ◆ Heavy-duty 12" x 12" cast iron grates
- ◆ 5" wide cool-touch stainless front steel plate rail provides safety and knob protection
- ◆ Standing pilot ignition system, one per burner
- ◆ 3/4" rear gas connection with regulator
- ◆ Conversion kit allows the use of propane or natural gas
- ◆ CSA listed for commercial and indoor use
- ◆ One year parts and labor warranty

### Models

#### NGHP-2

Burners: 2  
 BTU/total per HR: 50,000  
 Grate surface: 12" x 24"

#### NGHP-4

Burners: 4  
 BTU/total per HR: 100,000  
 Grate surface: 24" x 24"

#### NGHP-6

Burners: 6  
 BTU/total per HR: 150,000  
 Grate surface: 36" x 24"



NGHP-2



NGHP-4



NGHP-6

### Accessories

#### MINI UTILITY BRUSHES

- BR-7B 7" O.L., brass bristles  
 BR-7S 7" O.L., stainless steel wire bristles

#### SCRATCH BRUSHES

- BR-319 14" O.L., steel bristles  
 BR-500 20" O.L., wire bristles

#### For California Customers

**WARNING:** Cancer and Reproductive Harm - [www.P65Warnings.ca.gov](http://www.P65Warnings.ca.gov)

214-843-7078

[doug@redriverkitchens.com](mailto:doug@redriverkitchens.com)

[redriverkitchens.com](http://redriverkitchens.com)

Serving North Texas



# SPECTRUM Gas Hot Plates

Models:  
NGHP-2  
NGHP-4  
NGHP-6

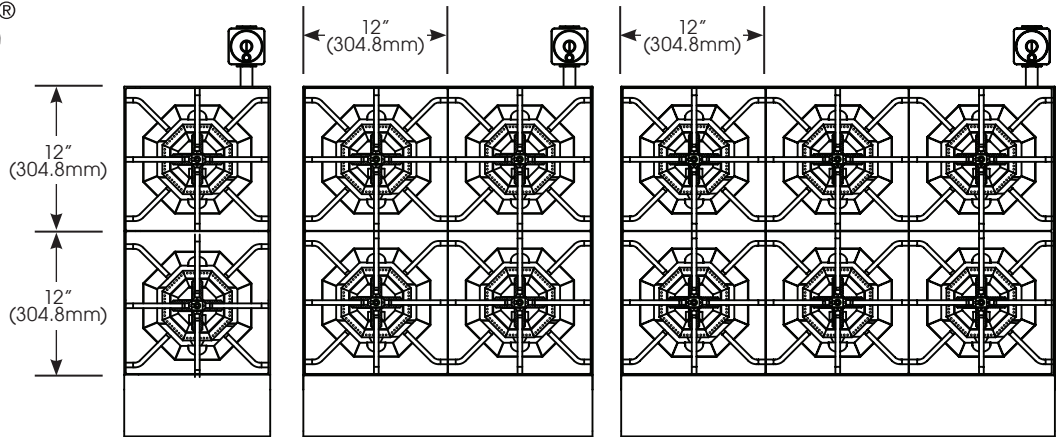

TOP VIEW

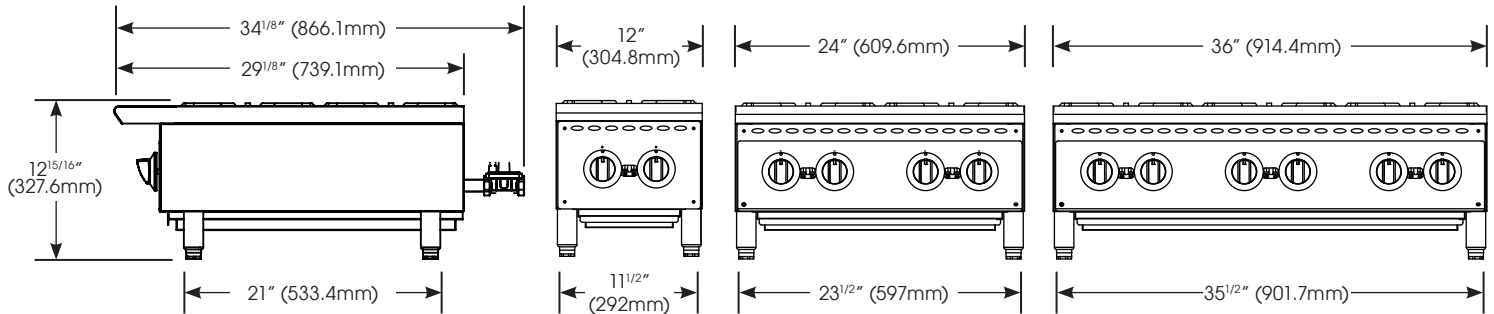

SIDE VIEW

FRONT VIEW

## Specifications

MODEL	DESCRIPTION	# OF BURNERS	BTU/ BURNER	TOTAL BTU/HR	PRESSURE IN. W.C.	DIMENSIONS			GRATE SURFACE		SHIP WEIGHT
						LENGTH	DEPTH	HEIGHT	LENGTH	DEPTH	
NGHP-2	Spectrum Gas Hot Plates	2	25,000	50,000	4" / 10"	12" (304.8mm)	34-1/8" (86.6mm) <i>includes gas inlet pipe at rear</i>	15" (381mm)	12" (304.8mm)	24" (609.6mm)	79 lbs (36 kgs)
NGHP-4		4		100,000		24" (609.6mm)			36" (914.4mm)		132 lbs (60 kgs)
NGHP-6		6		150,000		36" (914.4mm)			36" (914.4mm)		198 lbs (90 kgs)

## Gas Requirements and Information

- Natural or LP gas main supply required
- 3/4" NPT male connection, all units supplied with natural gas and convertible LP gas regulator

## THESE UNITS ARE SUITABLE FOR INSTALLATION ON NON-COMBUSTIBLE SURFACE(S) ONLY.

**Combustible clearances:** 6" sides (152mm) / 6" rear (152mm) / 4" floor (102mm)

**Noncombustible clearances:** 0" sides (0mm) / 6" rear (152mm) / 4" floor (102mm)

## Product Specs

### Gas Hot Plate

The Gas Hot Plate models NGHP-2 / NGHP-4 / NGHP-6 as manufactured by Winco®, Lodi, NJ 07644.

The Gas Hot Plate shall be rated at 25,000 BTU per burner, 3/4" rear gas connection with regulator and overall height from 13" to 15". The Gas Hot Plate shall consist of 12" x 12" cast iron grates, two (2) / four (4) / six (6) cast iron burners, standing pilot ignition system, stainless steel body, grease tray. Natural gas supplied standard. Conversion kit included for LP. Not to be used on casters.

CSA listed for commercial and indoor use.

Warranty consists of one year parts and labor.

